

Sym.	Description	Rev. No.	Date	Confirmed by
△				
△				
△				
△				

Q'ty	No.	Parts Name	Material	Remarks
1	1	PUSH PLATE	S45C	
1	2	DIAPHRAGM	TEFLON+EPDM	
1	3	FRICTION SHEET	TEFLON	
1	4	PUMP HEAD	P.V.C.	
2	5	BALL SEAT	P.V.C.	
2	6	CHECK BALL	CERAMICS	
1	7	SUC. BALL GUIDE	P.V.C.	
1	8	SUC. CONNECTOR	P.V.C.	
1	9	GASKET,SUCTION	VITON	
2	10	FLANGE	P.V.C.	KS 10K 15A/20A/25A
1	11	DIS. BALL GUIDE	P.V.C.	
1	12	HEAD CAP	P.V.C.	
1	13	GASKET, HEAD CAP	VITON	
1	14	DIS. CONNECTOR	P.V.C.	
1	15	GASKET, DISCHARGE	VITON	
1	16	HEAD COVER	P.V.C.	
1	17	O-RING	VITON	
1	18	O-RING	VITON	
6	19	HEX. BOLT	SUS304	
6	20	SPRING WASHER	SUS304	
6	21	PLANE WASHER	SUS304	
2	22	O-RING	VITON	
1	23	DRAIN VALVE	P.V.C.	

이 도면은 (주)이화정량펌프의 기술 자산입니다. 불법 유출시 관계법과 회사 규정에 의해 처벌 됩니다.

Projection		Trigonometry		Drawing Name	LIQUID END CONSTRUCTION
Scale	N / S	Unit	mm		
2004.06.25	H.J.SEO	W. PARK	W. PARK	S.C. KIM	Application
					EWS100~2000PCFD-15A/20A/25A FF
					Drawing Number
					A1300E3030

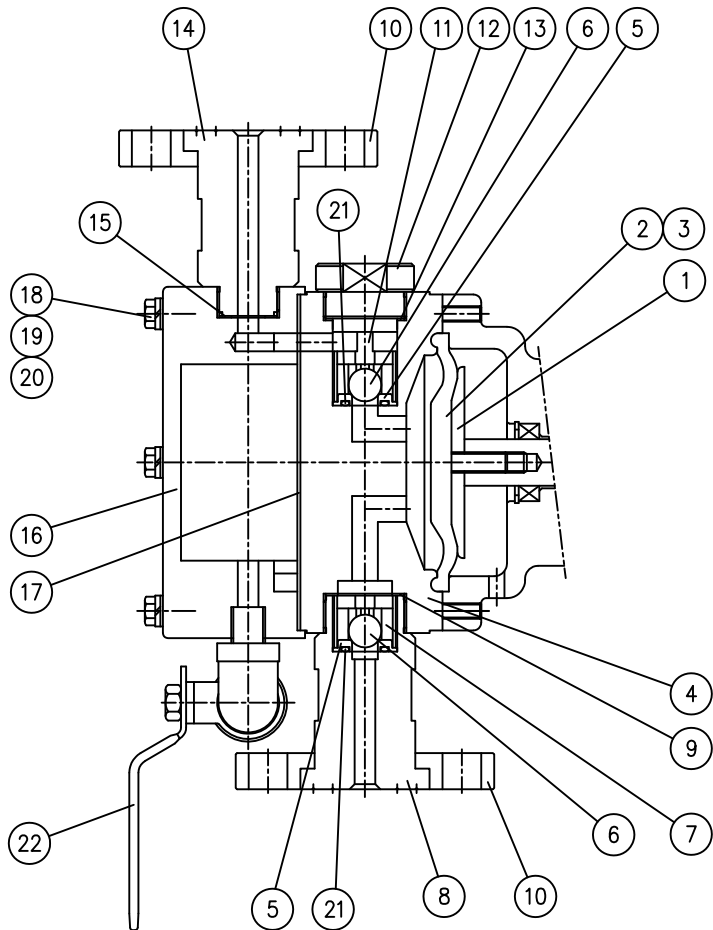

Sym.	Description	Rev. No.	Date	Confirmed by
△				
△				
△				
△				
Q'ty	No.	Parts Name	Material	Remark
1	1	PUSH PLATE	S45C	
1	2	DIAPHRAGM	TEFLON+EPDM	
1	3	FRICTION SHEET	TEFLON	
1	4	PUMP HEAD	SUS304	
2	5	BALL SEAT	SUS304	
2	6	CHECK BALL	SUS304	
1	7	SUC. BALL GUIDE	SUS304	
1	8	SUC. CONNECTOR	SUS304	
1	9	GASKET,SUCTION	VITON	
2	10	FLANGE	SUS304	KS 10K 15A/20A/25A
1	11	DIS. BALL GUIDE	SUS304	
1	12	HEAD CAP	SUS304	
1	13	GASKET, HEAD CAP	VITON	
1	14	DIS. CONNECTOR	SUS304	
1	15	GASKET, DISCHARGE	VITON	
1	16	HEAD CHAMBER	SUS304	
1	17	GASKET	VITON	
6	18	HEX. BOLT	SUS304	
6	19	SPRING WASHER	SUS304	
6	20	PLANE WASHER	SUS304	
2	21	O-RING	VITON	
1	22	DRAIN VALVE	SUS304	

이 도면은 (주)이화정량펌프의 기술  
자산이므로 불법 유출시 관계법과  
회사 규정에 의해 처벌 됩니다.

Projection		Trigonometry		Drawing Name	PUMP HEAD ASS'Y
Scale	1 / 2	Unit	mm		
Drawn by	Designed by	Checked by	Approved by	Application	EWS100~8000S4S4FD-15A/20A/25A FF
2000.10.15				Drawing Number	B3001E3032

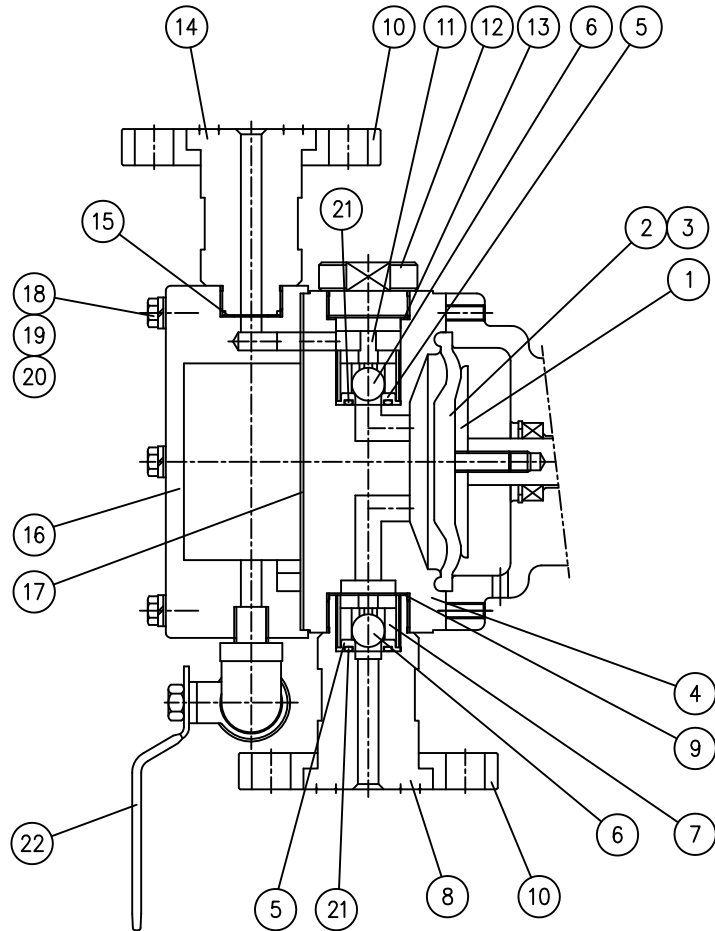

Sym.	Description	Rev. No.	Date	Confirmed by
△				
△				
△				
△				
Q'ty	No.	Parts Name	Material	Remark
1	1	PUSH PLATE	S45C	
1	2	DIAPHRAGM	TEFLON+EPDM	
1	3	FRICION SHEET	TEFLON	
1	4	PUMP HEAD	SUS316	
2	5	BALL SEAT	SUS316	
2	6	CHECK BALL	SUS316	
1	7	SUC. BALL GUIDE	SUS316	
1	8	SUC. CONNECTOR	SUS316	
1	9	GASKET,SUCTION	VITON	
2	10	FLANGE	SUS316	KS 10K 15A/20A/25A
1	11	DIS. BALL GUIDE	SUS316	
1	12	HEAD CAP	SUS316	
1	13	GASKET, HEAD CAP	VITON	
1	14	DIS. CONNECTOR	SUS316	
1	15	GASKET, DISCHARGE	VITON	
1	16	HEAD CHAMBER	SUS316	
1	17	GASKET	VITON	
6	18	HEX. BOLT	SUS304	
6	19	SPRING WASHER	SUS304	
6	20	PLANE WASHER	SUS304	
2	21	O-RING	VITON	
1	22	DRAIN VALVE	SUS304	

Projection		Trigonometry		Drawing Name	PUMP HEAD ASS'Y
Scale	1 / 2	Unit	mm		
Drawn by	Designed by	Checked by	Approved by	Application	EWS100~8000S6S6FD-15A/20A/25A FF
2000.10.15				Drawing Number	B3002E3032

이 도면은 (주)이화정량펌프의 기술  
자산이므로 불법 유출시 관계법과  
회사 규정에 의해 처벌 됩니다.

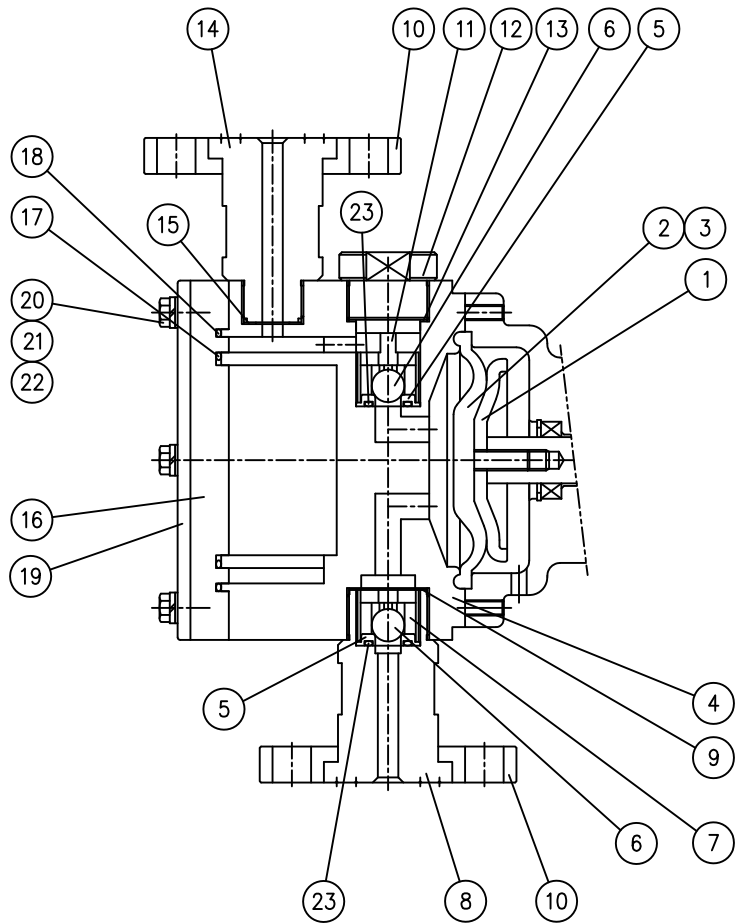

Sym.	Description	Rev. No.	Date	Confirmed by
△				
△				
△				
△				
Q'ty	No.	Parts Name	Material	Remark
1	1	PUSH PLATE	S45C	
1	2	DIAPHRAGM	TEFLON+EPDM	
1	3	FRICION SHEET	TEFLON	
1	4	PUMP HEAD	TEFLON	
2	5	BALL SEAT	TEFLON	
2	6	CHECK BALL	CERAMICS	
1	7	SUC. BALL GUIDE	TEFLON	
1	8	SUC. CONNECTOR	TEFLON	
1	9	GASKET,SUCTION	TEFLON	
2	10	FLANGE	P.V.C.	KS 10K 15A/20/25A
1	11	DIS. BALL GUIDE	TEFLON	
1	12	HEAD CAP	TEFLON	
1	13	GASKET, HEAD CAP	TEFLON	
1	14	DIS. CONNECTOR	TEFLON	
1	15	GASKET, DISCHARGE	TEFLON	
1	16	HEAD COVER	TEFLON	
1	17	O-RING	VITON	
1	18	O-RING	VITON	
1	19	REINFORCE PLATE	SUS304	
6	20	HEX. BOLT	SUS304	
6	21	SPRING WASHER	SUS304	
6	22	PLANE WASHER	SUS304	
2	23	O-RING	VITON	

Projection		Trigonometry		Drawing Name	PUMP HEAD ASS'Y
Scale	1 / 2	Unit	mm		
Drawn by	Designed by	Checked by	Approved by	Application	EWS100~8000TCF-15A/20A/25A
2001.05.16				Drawing Number	B3003E3031

이 도면은 (주)이화정량펌프의 기술  
자산이므로 불법 유출시 관계법과  
회사 규정에 의해 처벌 됩니다.

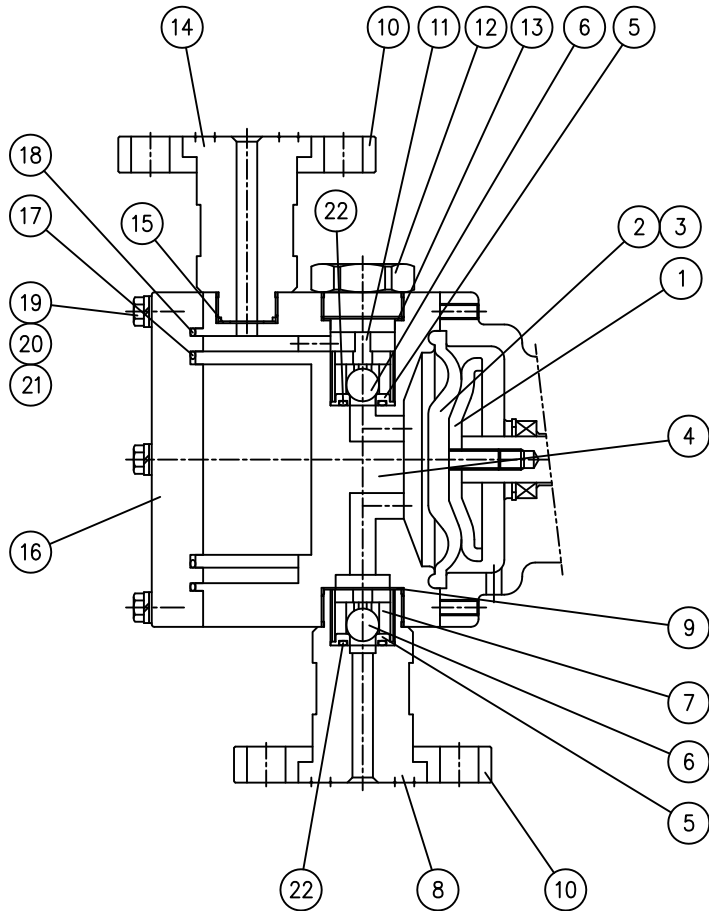

Sym.	Description	Rev. No.	Date	Confirmed by
△				
△				
△				
△				
Q'ty	No.	Parts Name	Material	Remark
1	1	PUSH PLATE	S45C	
1	2	DIAPHRAGM	TEFLON+EPDM	
1	3	FRICION SHEET	TEFLON	
1	4	PUMP HEAD	PVDF	
2	5	BALL SEAT	PVDF	
2	6	CHECK BALL	CERAMICS	
1	7	SUC. BALL GUIDE	PVDF	
1	8	SUC. CONNECTOR	PVDF	
1	9	GASKET,SUCTION	VITON	
2	10	FLANGE	P.V.C.	KS 10K 15A/20A/25A
1	11	DIS. BALL GUIDE	PVDF	
1	12	HEAD CAP	PVDF	
1	13	GASKET, HEAD CAP	VITON	
1	14	DIS. CONNECTOR	PVDF	
1	15	GASKET, DISCHARGE	VITON	
1	16	HEAD COVER	PVDF	
1	17	O-RING	VITON	
1	18	O-RING	VITON	
6	19	HEX. BOLT	SUS304	
6	20	SPRING WASHER	SUS304	
6	21	PLANE WASHER	SUS304	
2	22	O-RING	VITON	

Projection		Trigonometry		Drawing Name	PUMP HEAD ASS'Y
Scale	1 / 2	Unit	mm		
Drawn by	Designed by	Checked by	Approved by	Application	EWS100~8000KCF-15A/20A/25A
2000.10.15				Drawing Number	B3004E3031

이 도면은 (주)이화정량펌프의 기술  
자산이므로 불법 유출시 관계법과  
회사 규정에 의해 처벌 됩니다.

**EWHA** E-WHA CHEMICAL FEEDER CO., LTD.